

# Spa Owners Manual

THE COMPLETE GUIDE



# The Place for Total Relaxation

MIND, BODY & SOUL

NOTE DIRECT HOT TUBS IS A  
TRADING NAME OF COMBINED  
SHIPPING CO LTD

# Contents

Introduction	Filter Maintenance
Main Functions	Control Panel Maintenance
Safety Guide	Pillow Maintenance
Positioning & Location of Spa	Pump Maintenance
Electrical Installation	LED Light Maintenance
Filling Your Spa	UV Disinfection Maintenance
Adding Chemicals	Ozone Generator
Dosage Instructions	How to Replace UV Lamp
Spa Range Water Capacity	How to Replace Quartz Sleeve
Operating Jets, Air Valves, Diverters & Water Flow	Aroma Canister
Draining Your Spa	When Spa Not In Use
Spa Clean Maintenance	How to Assemble Step
Water Maintenance	How to Assemble Cover lifter
Common Water Problems	Trouble Shooting

# Spa Quick Set-Up Guide

Note: All Spas are slightly different in configuration and this is for guidance only, but the principals remain the same. Please refer to your Control Panel Manual and Chemical Guide for detailed advice.

## 1. Remove Side Panels

Use **hand screw driver (to avoid threading screws)** to remove 4 screws for the panels directly under the control panel.

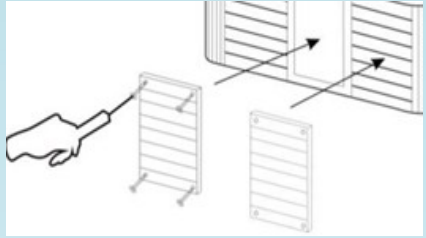

Control Panel



## 4. Fill Your Spa

Fill your Spa using a hose pipe through the filter housing (to avoid airlocks). This can take several hours. Ensure you fill 4" to 6" below top edge of spa, all jets need to be covered with water. **Check pipe unions again. Note: Make sure cellophane is removed from filter, which is situated in the housing.**



Filter Housing



## 5. Switch Power On to Spa

Control system will go through a priming cycle for 5 minutes, pre-set temperature is normally 37 degrees. Refer to manual for full set-up guide.



## 6. Add Chemicals

Once Spa is over 20 degrees (approx. heats up 1 degree per hour), add your chemicals. Refer to manual for full set-up guide.

## **\*\*Important Note – Keep Filters Clean\*\***

An unclean filter will cause damage to the heater and pumps. For best results we recommend you jet wash them once a month, depending on usage.



## 2. Check Pipe Unions

These can become dislodged during transit, turn them slightly to ensure tight fitting to avoid leaks. Check them again once filled with water.



## 3. Connect Electrics (under control panel)

Ensure you use a fully qualified electrician. If you do not install your electrics correctly, it will invalidate your warranty. The 13amp Plug & Play versions come with cable and plug, however, it is recommended a 13amp RCD is used, other models do not come with cable.

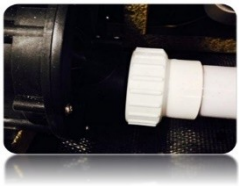

# Introduction

Welcome to your new spa, with the correct preparation and care, your new spa will provide you with many years of fun and relaxation.

This manual has been developed to provide you with the information that you need regarding the preparation, installation, care and operation of your new spa. Please take the time to carefully read the entire manual to ensure that your spa preparations are carried out correctly. Also make sure that you familiarize yourself with the important safety instructions before using your spa.

If you have any question on the operation or maintenance of this product, please contact us, we are available 9am - 7pm Monday to Friday and 10am – 4pm Saturday & Sunday .

# Main Functions & Product Characteristics

**Hydrotherapy function:** The product comes with special hydrotherapy seats which are designed according to ergonomic engineering, different kinds of jets in the seat to help to achieve body therapy. Adjust the massage pressure by adjusting the face, water diverter and air regulator.

**Air bubble therapy function:** Turn on the air blower, specially designed air jets will blow lots of air bubbles to provide you bubble therapy and fun.

**Heating function:** SPA comes with heater, once the user set the temperature, the heater will start to maintain the temperature to the set temperature and ensure the spa is available for all season. **Make sure to put the insulation cover on the spa when it is heating.**

**Filter and circulation function:** SPA comes with filter which can clean the impurities inside efficiently, meanwhile, the system will run the filter cycle programming automatically, to kill the bacteria via the ozone released by the ozone generator.

**Lighting:** The spa is fitted with an underwater light. The colour and mode of the light can be changed via the control system touch panel, helping you create an ambiance to suit your mood.

**Aromatherapy function (option):** This spa is fitted with an aromatherapy canister which contains scented oil. The soothing scent is dispersed into the water through special plumbing to help you relax.

**Swimming (swim spa):** Adjust the swim jets to create a powerful current which allows you to enjoy endless swimming without taking up a lot of space.

**Exercising (swim spa):** With the help of an exercise band or swimming harness, you are able to do all kinds of exercise in swim spa.

**IMPORTANT DECLARATION:** All functions mentioned above are a general introduction to our spas products, The SPA you purchase may be different. Please check it thoroughly before purchasing. The manufacturer reserves the right to modify and improve the product when necessary without prior notice and without entering into any obligation.



# Safety Guide

It is essential to familiarize yourself with general spa pool safety and water treatment procedures. Please make sure to familiarize below contents:

## **Drainage requirement:**

Ensure that the spa is not in a low or floodable position; as this could cause electrical equipment shortage or be dangerous to spa users.

## **Risk of electric shock:**

As with all electrical appliances there is a risk of electrocution, the engine room within the cabinet houses the control unit that operates the spa, the door enclosing the unit should always remain shut. If water happens to enter the engine room, turn the spa off at the power outlet and make sure all the components are dry before attempting to power the spa back up.

## **Temperature:**

Keep your spa water temperature no higher than 40°C., the higher water temperatures can cause strain on the cardiovascular system. If the water temperature is higher than 40°C, get out of the spa and contact us as soon as possible. It is recommended that the water temperature be no higher than body temperature i.e. 37.5°C.

## **Medical conditions:**

- People with diabetes, high blood pressure, heart disease or other cardiovascular conditions should consult their physician before using a SPA.
- People with open sores or any type of infection should not use the spa.
- Hot water is an ideal environment for spreading infection, especially if sanitizer levels are not properly maintained.
- Women who are pregnant should consult their physician before using a spa.
- To reduce the risk of contaminating spa water and minimize health risks, shower with soap and water prior to using the spa.

# Safety Guide Continued..

**Soak and cool time:** Limit spa use to no more than 15-20 minutes at a time. Some spa pools are equipped with a cooling seat, so when you feel you are getting too hot, sit on the cooling seat and allow your body to cool. When you feel comfortable you may submerge yourself back into the spa pool. Sitting in the spa with your head above the water level will dramatically decrease the time it takes to cool down. Hyperthermia may be fatal. Do not expose your body to prolonged exposure in water above normal body temperature.

**Alcohol use and medication:** The consumption of alcohol in and around the spa pool is a hazardous practice. Never use glass drinking vessels near the spa pool. Alcohol can cause drowsiness and lead to drowning. Any person taking medication should consult their physician before entering the spa pool.

**Safety:** This appliance is not intended for use by persons (including children) with reduced physical, sensory or mental capabilities, or lack of experience and knowledge, unless they have been given supervision or instruction concerning use of the appliance by a person responsible for their safety. **Children should be supervised always.**

**Preventing slips:** Always take care when entering and exiting a spa due to slippery, uneven surfaces. Handrails and non-slip surfaces will help to minimize the risk of slipping and falling. In some cases, steps may be needed to make entering the spa easier.

**Electrical appliances:** Never have any electrical devices within 2 meters of the spa.

**Weather conditions:** Do not operate or soak in a SPA during severe weather conditions i.e. thunderstorms or electrical storms.

**Ventilation:** If the SPA pool is not sufficiently ventilated some people may experience throat irritations. Make sure that the SPA pool is properly ventilated if you are installing it in an enclosed area.

**Chemicals:** Ozone and UV disinfection help reduce the application amount of chemicals in the spa. But SPA chemicals are still necessary to control bacteria, prevent infection and maximize the life of your SPA and its equipment. However, in concentrated form of these chemicals, like other household chemicals, can be hazardous. Always handle and use them with care. Refer to the product's label for safety and handling information. A more in-depth explanation on how to use chemicals in your SPA can be found in the Chemical Management section.



# Positioning & Location of Spa

Position your Spa in an area that is very well supported and solid enough to take the weight of the Spa including the water and the people enjoying the product, you could take advice from a structural engineer or your builder if in any doubt. Ensure that the Spa is properly supported by either a level concrete pad, or a properly constructed deck capable of supporting 1220kgs /m<sup>2</sup> (250lbs./ft.<sup>2</sup>).

A concrete base should be at least 4" thick and it not advisable to put your Spa on an elevated wooden platform without sound advice, again due to weight issue, the general message is "these things are heavy".

Avoid placing the SPA where water could flood into the electrical equipment compartment, and also protect the unit from direct contact with very damp areas.

It is recommended to place the SPA away from trees, as falling leaves may block the filter.

Your spa needs to be positioned so that the spa's equipment is easily accessible. The equipment is located (in most cases) at the front of the SPA and will need access for service and power connection. It is recommended that you have access to all sides allowing at least 1/2 a meter access around all 4 sides of your SPA for future access if required. It will be the owner's responsibility to make sure this is completed prior to the service being carried out. All portable SPA equipment must be ventilated. Do not obstruct any vents in the cabinet.

Important Note: DO NOT leave your SPA in direct sunlight for extended periods of time and doing so may void your warranty. The SPA has covered insulation foam over the shell and pipework and if left exposed to direct sunlight the surface temperature can build up to 200 °C causing damage to your SPA. It is suggested that you not only have the hard cover over your SPA while not in use but also have the SPA in an area which is sheltered from extreme and harsh weather conditions. Leaving the SPA uncovered and exposed may void your warranty on your SPA and its accessories

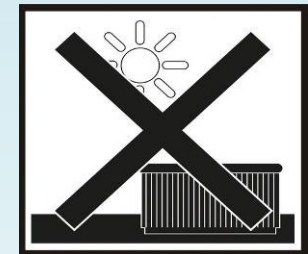
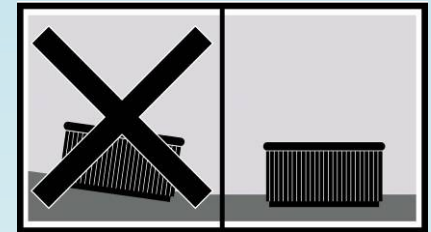

# Electrical Installation (IMPORTANT)

- The power supply should be: 380V/50HZ-60HZ or 220V/50HZ-60HZ.
- You are advised to apply the 5×6mm<sup>2</sup> cable for 380V power or the 3x10mm<sup>2</sup> cable for 220V power.
- The electrical supply to your new spa will require a dedicated circuit with no other appliances or sockets sharing the power.
- Electrical burnout due to incorrect amperage WILL NOT be covered by warranty.
- Only a fully qualified electrician may be used for electrical installation.
- Ensure the main power supply has installed high sensitive leakage protectors. Recommend 30mA leakage protectors.
- Ensure there is a minimum of 2 metres distance between isolator/socket and Spa.
- Ensure your new SPA is safely earthing as right figure. Please refer the control system instruction manual before electrical installation.
- 13 amp Plug & Play models come with 3 metres of cable and UK plug, it will require an outdoor waterproof plug sock with RCD protection.
- You are advised to drill a dia. 26mm cable hole on the bottom of one corner skirt that is near the control box as right figure for the cable

**13 AMP**

13 amp models require an outdoor waterproof plug socket with RCD protection.

**COMBINED SHIPPING COMPANY LTD.**

**Electrical Requirements**

**32-40 AMP**

6mm 3-core SWA cable is needed for a 32AMP Hot Tub and a 10mm 3-core SWA cable for a 40 AMP Hot Tub.

**Or for 32 AMP**

Or 6mm SWA cable with RCD protection with a commando socket with local isolation.

### Electrical Safety & Regulations

Section 702 of the 17<sup>th</sup> Edition Wiring Regulations (BS 7671:2008)

A 2.0m Minimum Safe Distance from Electrical Junction Box or Socket is Required

# Filling Your Spa

- Before filling your spa, please check and tighten all the unions, as they may have come loose during transit.
- Please check and make sure all the check valves are all in the open position.
- Check that the drainage valve is shut off.
- Check that all jets are in the open position. Swivel anti-clockwise to turn your jets on.
- Fill your SPA with water. **Make sure to fill the water through filter area every time in order to prevent air block in the pumps.**
- Fill water to the line on the water level indicator as the figure which is 4" to 6" (100 to 150mm) below the top edge of the spa. Do not overfill as the spa's water level will rise as each person enters the spa.

The required Water Level



# Adding Chemicals

Once you have filled your Spa with water, you will need to add your preferred Sanitiser. Ideally wait until the Spa is above 20 degrees Celsius so the chemicals will dissolve quicker. Add chemicals as instructed below with pumps on, leave for 5-10 mins before replacing cover.

## **CHLORINE**

Chlorine is the most commonly use sanitiser and an effective way to kill bacteria in your water. If you have skin reactions to Chlorine then you can use Bromine, the only downside to Bromine is that it is a slower reacting chemical and not as effective at killing bacteria.

### **Chlorine Granules**

### **Level 3-5 PPM**

If you are using Chlorine Granules you need to keep your level of Chlorine between 3-5 ppm (parts per million). Simply sprinkle the granules into the water with the pumps on, leave for 5-10 minutes then turn off the pumps and replace the cover.

## **BROMINE**

Favoured and recommended by many Spa and Hot Tub suppliers, as it is kinder on the skin particularly if you have children, it is also less volatile at high temperatures.

### **Bromine Granules**

### **Level 4-6 PPM**

If you are using Bromine Granules you need to keep your level of Bromine between 4-6 ppm (parts per million). Simply sprinkle the granules into the water with the pumps on, leave for 5-10 minutes then turn off the pumps and replace the cover.

Leave for 24 hours and check your levels with the ph Test Strips, you should be able to smell the chemicals. Maintain the pH balance between 7.4 and 7.6 and alkalinity level of 125ppm – 150ppm. It is easier to correct if under dosed, rather than if it has been overdosed – so go easy with the chemicals!

### **Bromine Tablets**

A very easy to use and cost effective sanitiser, simply put 3-5 tablets in a floating dispenser and adjust the collar accordingly. Allow 24 hours for the tablets to take effect and check bromine levels with ph Test Strips, maintaining a bromine level of 4-6 mg/l. Tablets will take 10-14 days to dissolve, check regularly and keep between 3-5 tablets in dispenser at all times.

# Dosage Instructions for Chlorine/Bromine

<b>Water (Litres)</b>	<b>Add Chlorine (Weekly)</b>	<b>Bromine (Weekly)</b>
600-800	$\frac{3}{4}$ Teaspoon/Capful	$\frac{3}{4}$ Teaspoon/Capful
900-1200	1 & $\frac{1}{2}$ Teaspoons/Capfuls	1 & $\frac{1}{2}$ Teaspoons/Capfuls
1300-1500	2 Teaspoons/Capfuls	2 Teaspoons/Capfuls
1600-1800	3 Teaspoons/Capfuls	3 Teaspoons/Capfuls

# Spa Range Water Capacity

San Marino	650 litres	Sunset 4	<b>1450 litres</b>
Twin	900 litres	Neva Plus	1100 litres
Sure 3	1150 litres	Rhine	1150 litres
Moonlight	1200 litres	Milano	1100 litres
Tiny	600 litres	Munich	1100 litres
Georgia	1150 litres	Volta	1470 litres
Tennessee	750 litres	Atlantic	1600 litres
Harmony & Harmony P	800 litres	Nevada	1450 litres
Horizon	800 litres	Neva	1100 litres
Destiny	1500 litres	Orion 4	650 litres
Niagara	1600 litres	Orion 6	1400 litres
Aurora	1800 litres	Orion 8	1680 litres
Ultimate & Ultimate Plus	1650 litres		



# Operating Jets, Air Valve, Diverters & Water Flow

**Jets** are the main parts in which massage comes into effect and almost all of the jets in your spa are adjustable. You can adjust the water flow through by rotating the jet face.

- Turn the jet face clockwise about 1/4 of a turn, the jets are turned on.
- Turn the jet face anti-clockwise about 1/4 of a turn, the jets are turned off.



**NOTE:** Some jets and the air jets are adjustable, do not rotate these jets with force as it may cause damages to the jets.

**Air valve:** Air controls affect the pressure of your jets by adding air, you may have more than one air valve on your spa, each of which will be associated to a certain group of jets. By opening an air valve when the pump is on, air will be drawn into the water flow to increase the massage strength.

- When the air valve is turned clockwise, it will decrease the power of the massage jets.
- When it is turned anti-clockwise, it will increase the power of the massage jets.

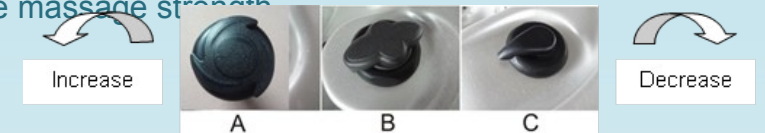

**Water diverter:** Your spa may be equipped on one of the below water diverters. Rotating the water diverter, you will divert the massage power of different seats.



**Water flow switch:** The water flow switch controls the flow of water to the options, such as waterfalls and fountains. Rotating the water flow switch will turn on, turn off and adjust the water flow



# Draining Your Spa

If you use your SPA once or twice a week, the need to drain your SPA will be less frequent than a owner who uses their SPA three or more times a week. Therefore, it would be recommended that a SPA be drained at least every 3 months.

There are several kinds of drainage valves as per different spas, there is the side drain valve on the skirt panel and the corner drain valve is positioned at one corner of the bottom base.



1. Open the skirt panel of drain valve to open the red ball valve (the ball valve connecting to the black drain valve is closed out of factory).



2. Remove the cap of the drain valve by turning it anti-clockwise.



3. Connect a 3/4 inch hose or screw a standard male hose fitting onto the valve and connect your hose.



4. Turn the valve anti-clockwise to the end and then pull out the valve forward to drain the water.



- **NOTE:** Ensure the power is shut off before draining. Equipment damage caused by dry running will not be covered under warranty.
- **DISPOSAL OF WATER:** Do not drain water onto your lawn or plants unless all of the bromine or chlorine has dissipated from the water. The sanitizer in your water will dissipate quickly by leaving the cover off and exposing the water to direct sunlight.

# Spa Clean Maintenance

Owning a spa is fun, relaxing and therapeutic, but more importantly we must look after our investment to keep it healthy and economical, thus avoiding unnecessary premature repair costs.

## SPA surface clean and maintenance:

The spa surface is made of high-glossy acrylic and must be kept clean and it is suggested to clean the spa outside water line once a week and clean the whole spa after drain. Details steps as below:

- Clean the dirt with wet towel, you can use the neutral detergent and soft towel, but cannot use the detergent which with ketone or chlorine water.
- If the surface has some light scratch, please polish it with 2000# sand paper and then make up it with toothpaste, re-polish it with soft towel.
- Please do not clean the spa surface with any chemical solution or crude tools; do not scratch the spa surface with hard material or knife.
- Please do not clean the spa surface with nail polish, nail polish remover, dry detergent, acetone, paint remover etc. It will damage the surface.
- Do not touch the spa surface with any heat source over 70°C.

# Water Maintenance

Are you having issues with your hot tub water? Perhaps skin irritation after going in the spa? Or is your water not quite right?

It is extremely important to keep your pH levels **between 7.2 and 7.8** - having pH levels that are higher than 7.8 or lower than 7.2 can cause problems not only for the hot tub but also for you!

**A pH level which is too high** causes calcium build up, it also causes people to often experience itchy skin and burning eyes. Keeping your Chlorine levels where they should be is also much more tricky when your pH level is too high.

**A pH level which is too low** can cause your hot tubs metal components to corrode which will be expensive to replace and void your warranty. As with high pH people will experience itchy dry skin and burning of the eyes and nose. Low pH causes rapid dissipation of chlorine requiring more frequent additions of the chemical to keep the levels correct.

In order to avoid this its important to use your pH test strips to check your pH levels on a regular basis, especially just before getting in.

If you do encounter a problem with high pH, use a pH Decreaser product to get it back within the correct range. If your pH is too low, use a pH Increaser product to raise the level.

Keeping your hot tub's pH levels correct will create a more comfortable environment, help you avoid scale and calcium build up, and help keep your hot tub equipment free of corrosion

# Common Water Problems

Simply by keeping on top of the water condition and chemical levels you can easily ensure the water is completely sanitary and that the spa experience is enjoyable for everyone

**Common Water Problems:-** Water is Cloudy, Water is a Milky Colour, Excess Foam, Water is Green

**Possible Cause:** - Dead algae particles, Debris from the environment, Bad filtration, Lack of sanitizer (i.e. chlorine/bromine), High pH and/or alkalinity, Body oils, lotions, and other human elements

**Cloudy Water** is often a build up of particles in the water caused by either dirty filters, excess oil, organic matter or incorrect sanitation levels. In order to rectify, clean filters, check water balance levels, add Spa Shock or Spa Sparkle.

As a last resort if these methods do not improve the situation it is advised to drain, clean and refill the Hot Tub with fresh water.

**Milky Water** is a white film on top of the Hot Tub usually caused by dirty filters, algae, poor water chemistry, insoluble particles. In order to rectify clean filters, check water balance levels, add Spa Shock or as a last resort if these methods do not improve the situation it is advised to drain, clean and refill the Hot Tub with fresh water.

**Foamy Water** can be the build up is caused by a reaction between body and cosmetic oils combined with the alkalinity of the Hot Tub water. Body oils and cosmetics such as deodorant, makeup, hairspray, shampoo etc. Ideally you should shower before getting into a hot tub in order to remove any hair gel, skin lotions/creams and to generally cleanse your skin. There are *two* common types of foam in a spa:

## **A detergent or surfactant-based foam**

Usually uniform bubbles often with a rainbow effect on the bubbles when viewed in the right light. This type of foam is common when surfactants mix with oils (soap) or stain and scale inhibitors (surfactants to reduce water tension to reduce scaling from chemicals like calcium) mix with oils to produce soap in the water.

## **Organic Build up**

In a spa this is body oils, skin creams, cosmetics etc that accumulate in the water and make varying sized, creamy, scummy bubbles with particles on them. You see this foam most often shortly after shock treating the water.

In order to resolve these issues use Foam Away or part empty your Hot Tub and flush the system.

**Green Water** is not a good colour for Hot tub water, it indicates that your Hot Tub has active bacteria growing in the water. It is advisable not use until problem is solved by draining water out then scrub all surfaces with a chlorine solution, rinse out with clean water and refill with clean water. Shock dose the spa with a combination of Chlorine and Non Chlorine.

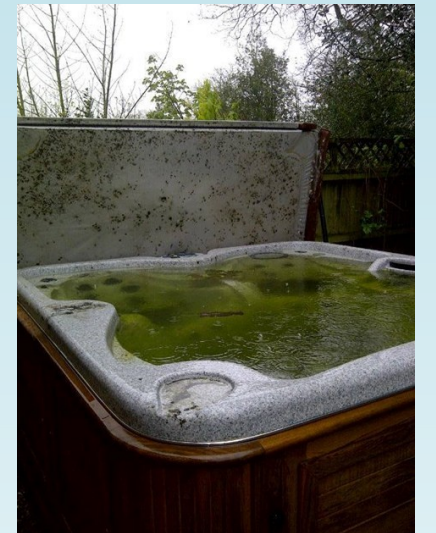



# Skimmer Maintenance

There are two styles of skimmers, a lifting skimmer or wall-mounting skimmer.

## How to remove the paper filter from the lifting skimmer



## How to remove the paper filter from the wall-mounting skimmer:

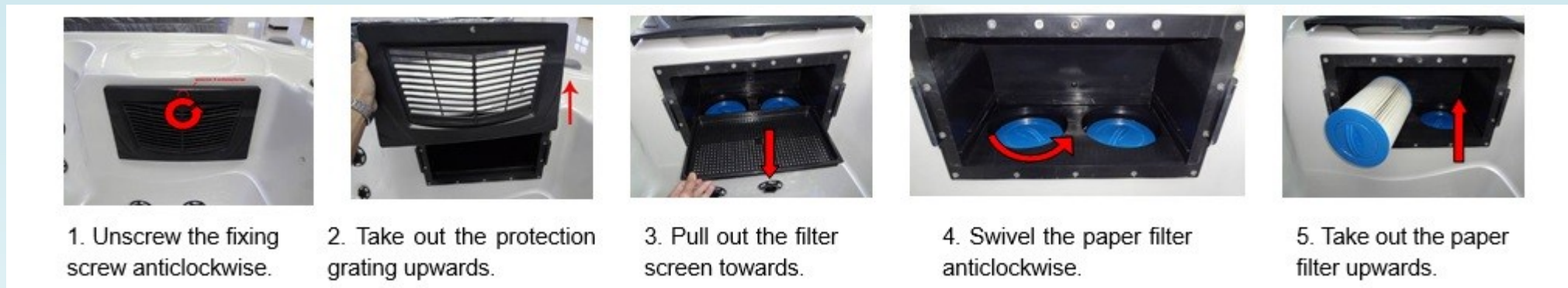



# Filter Maintenance

In order to avoid damage to your Spa, you will need to clean your filter on a regular basis.

Remove your filters and spray the debris out of it with a high pressure hose once a week or soak your filters in a cartridge filter cleaning solution and then spray it with a high pressure hose once a month.

## How to Remove Filter

- Cut off the power of the spa to avoid debris being sucked into the circulation, pump or heater.
- Remove the paper filter by turning it counter clockwise
- Clean the paper filter by spraying water from top to bottom at a 45° angle as the figure below to remove debris.
- Replace your filter every 3-6 months.



# Control Panel Maintenance

The control panel is glued on the tub shell by silicon sealant. If you need to replace it, use a blade to take it out from the shell.

For daily use:

- Do not touch the control panel with hard objects to avoid scratching.
- Avoid prolonged direct sunshine on the control panel.
- Keep the control panel covered when not in use.

# Pillow Maintenance

Your spa may be installed one of the two kinds of pillow as below, you can remove the pillows for cleaning and maintenance quickly and easily.

**Fixed pillow:** Grab the lower edge of the pillow with both hands firmly and pull up. As you do this, the pillow inserts will pop out of the holes. Reseat the pillows by aligning the pillow inserts with the holes and striking the pillow hard enough to insert the pegs back into the holes.

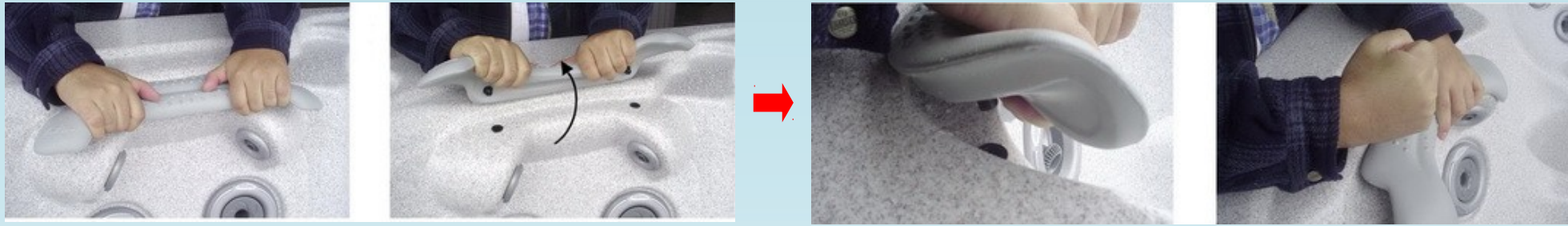

**Adjustable pillow:** Grab the pillow and pull it upwards to lift the pillow. Lower the pillow by pressing the button on the bottom.

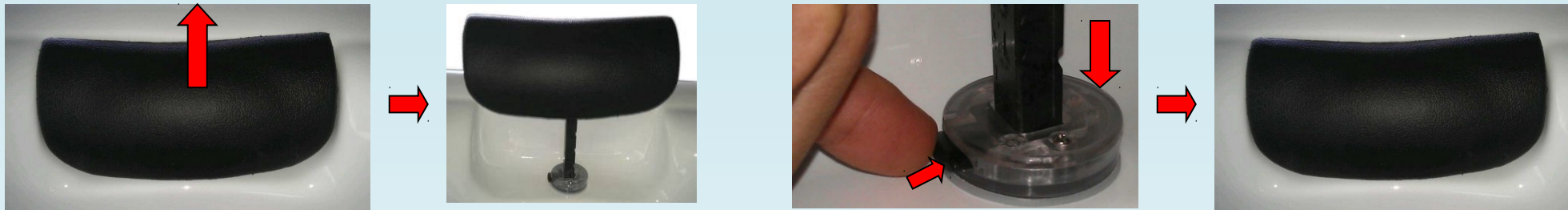

## NOTE:

- Clean the pillow with neutral detergent
- Excessive chemical levels and ozone may cause fading of headrests.
- Fading is not covered by warranty.

# Pump Maintenance (air locks)

If you have emptied and refilled your spa and the pump comes on but there is no water movement in your spa, the spa is probably suffering from an air lock. This situation is more often for circulation pump than other massage pumps. To get the air out of your pump, turn the spa off and find the circulation pump, which is situated inside the spa cabinet. Locate the pipe which goes into the top of the pump. This has a large nut, which is called the barrel union. Undo anti-clockwise until you hear the air escape. When the water comes out, re-tighten. This should fix the airlock. Sometimes you have to start the pump again to remove the air

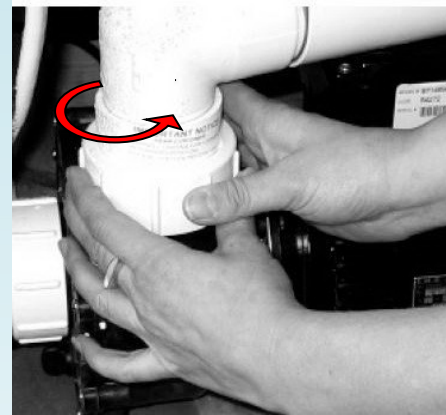

# LED Light Maintenance

Your spa will be equipped with one kind of LED lights as below. If the LED lights are not on or its colour is different from other lights, you will need to replace it. LED Lights are covered for 1 year on warranty, and it is the Owners responsibility to replace them as no labour included.

**How to replace the plug-in style LED lights:** pull out the defective LED light from its holder on the tub shell and the white socket. And then insert the new light to the holder and socket accordingly.



**How to replace the buckle style LED lights:** pull out the defective LED light from its holder on the tub shell and swivel the black buckle anti-clockwise. And then put the new light to the holder and buckle accordingly.

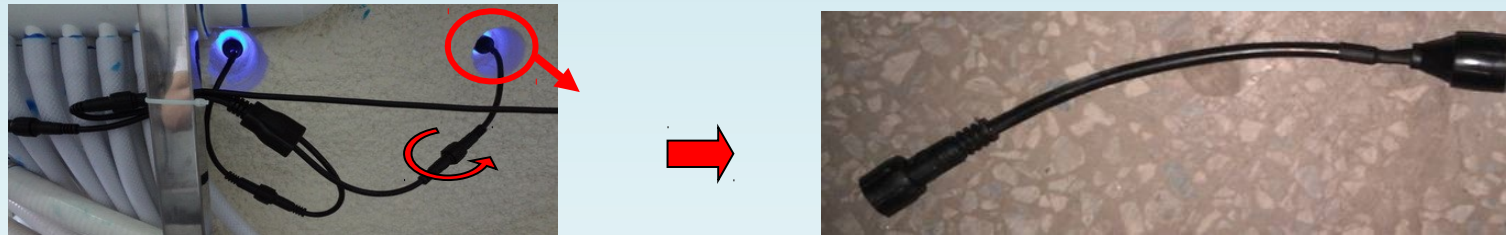

# UV Disinfection System & Maintenance (optional)

Ultraviolet disinfection can sterilize water in an effective and efficient way. Ultraviolet energy can destroy bacteria and virus in about 1-5 seconds. In order to reach the same disinfection effect, it costs the other chemicals methods (Chlorine, Chlorine dioxide, ozone) about 30 minutes or more contact time. Besides, UV disinfection is a physical process. During the disinfection process, it doesn't produce any byproduct and there is no abnormal flavor in the water after treatment. The UV system works automatically once the circulation pump is running. There are two indicator lights on the power box of UV system. The green light on means it works correctly; the red light on means there is problem with it.



Indicator light of UV system

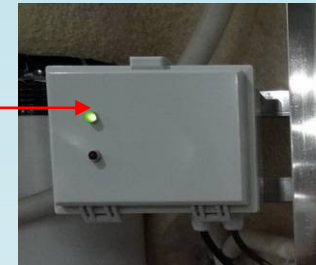

It is mandatory that the UV lamp (part ④) is replaced at the least 12 months to maintain optimum performance.

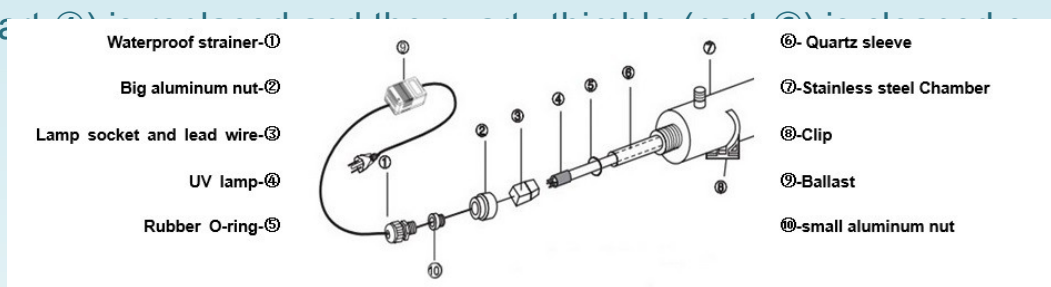

every 12 months to maintain



# Ozone Generator

Ozone or O<sub>3</sub>, is an oxidizing chemical compound, which is very effective for disinfecting water. The main advantage of ozone is that it leaves no chemical trace and is odorless. Generally, the spa is equipped with one ozone generator which produces 50mg ozone per hour. Ozone disinfection is an automatic process and resulting ozone is injected into the water through the ozone injector, ozone mixer and coming out from the ozone jet (it is one of the four black circulation jets at the bottom of the tub, you can see there are air bubbles coming out from it in the water). The ozone generator works automatically once the circulation pump is running. The indicator light of ozone generator will be on when it is working. You can open the skirt panel to check it.

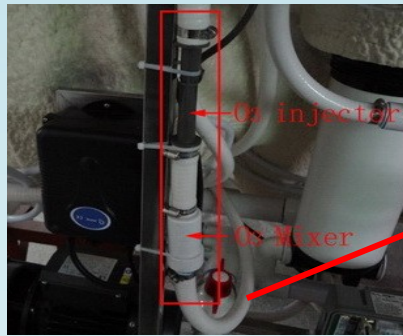

Indicator light of ozone generator



# How to Replace UV Lamp

Loosen the waterproof strainer (part ①) and then swivel the small aluminum nut (part ⑩) anti-clockwise to take the UV lamp out. Pull out the old UV lamp (part ④) from the socket (part ③) and then insert the new one to it and then put it to the chamber (part ⑦) again. Do not loosen the big aluminum nut (part ②) when you replace the UV lamp. If not, the water will come out from the entry of chamber.

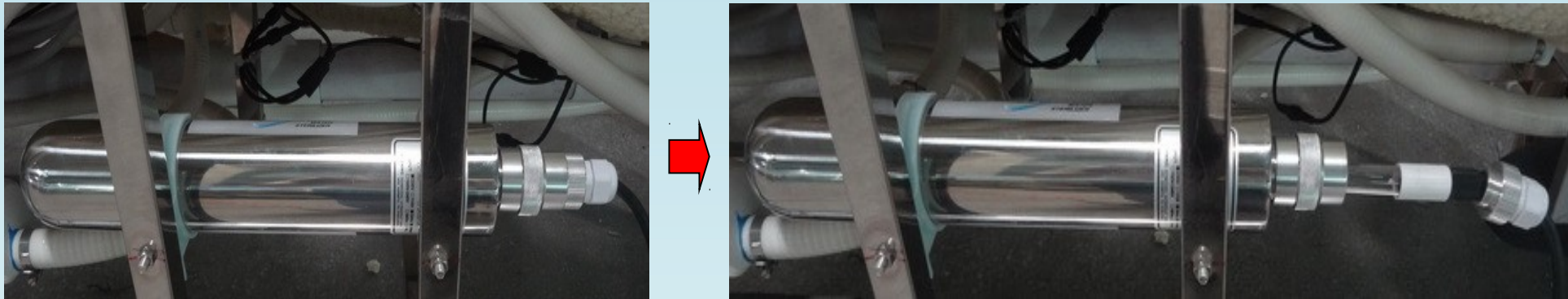

**WARNING:** Germicidal ultraviolet rays are harmful to eyes and skin. Do not open the UV chamber when it is still powered on.

# How to Replace Quartz Sleeve

Before replacing or clearing the quartz sleeve (part ⑥), you are obligated to close the two small ball valves on the inlet and outlet of the chamber. If not, the water will come out from the entry of the chamber.



1. Fix the UV chamber vertically and then insert the quartz sleeve



2. Put the O-ring on the quartz sleeve



3. Slid down the O-ring to the outlet of the chamber



4. Tighten the big aluminum nut to the chamber

# Aroma Canister (optional)

The Aroma canister is the part that brings aromatherapy. The aroma canister is connected to the air blower of the spa and is composed by aroma canister cover, aroma canister and canister holder. Turn the canister knob clockwise to open and increase the aromatherapy; turn the canister knob anti-clockwise to decrease and close the aromatherapy.

Make sure to remove the sealing cover of aroma canister before first use and to help aromatherapy oils last longer, remember to turn the aromatherapy canister off when the spa is not in use.



**Aroma canister maintenance** Replace the lasting scents essential oil in 2 or 3 months time accordingly. Turn the canister cover (part A) anti-clockwise to open it (fig. ①). Turn the canister knob (part B) anti-clockwise to take it out (fig. ②). Check if it is any lasting scents essential oil left. Replace it when it is empty. Remember to remove the sealing cover (part D) of aroma canister before putting it into the holder (fig. ③④⑤⑥). You can contact the local dealer to get a new one for replacement.

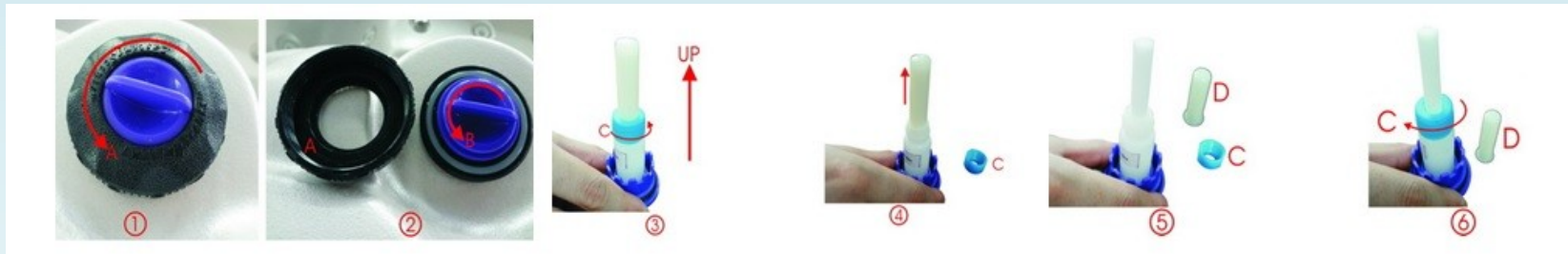

# When Your Spa is Not in Use

- If you are going away for a period longer than 2 months, it is recommended that you turn your spa off and empty it. It is important to remember to leave the cover on even while empty to protect the shell. If you are going away for a few days or weeks, do not turn your spa off completely. Turn the temperature down to 15 degrees, so that the filtration cycles are still functioning but the spa doesn't heat.
  - **3-5 days:** Test PH and sanitizer levels of the spa water and adjust it if necessary, cover the spa; test water balance and adjust if necessary before using the spa again.
  - **5-14 days:** Setting the lowest temperature or sleep mode. Adjust the PH and water treating, cover the spa cover, adjust the PH and water treating when you reuse the spa.
  - **More than 15 days:** Turn off the power, open the drain valve and drain the spa, remove the paper filter, keep the spa dry and put the spa cover on.



# How To Assemble Step

The step will need to be assembled, the reason we do not assemble the step is to save on the packing space. Follow below step by step instructions:-

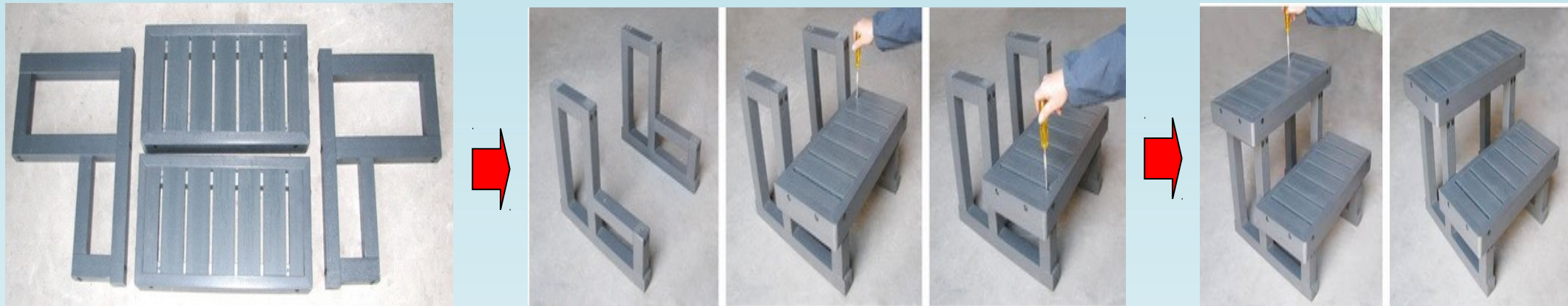



# How to Assemble the Cover Lifter

- We have various types of Cover Lifters, Cabinet Attached Basket, Up & Over & Stand, these are all supplied with instructions enclosed within packaging

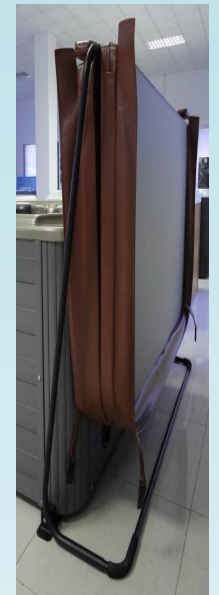
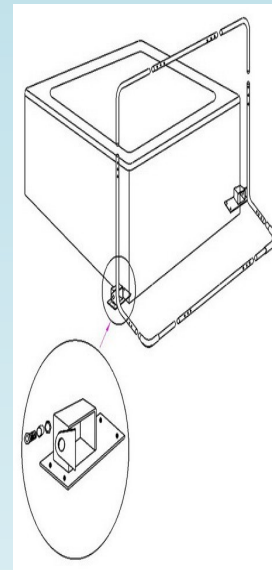
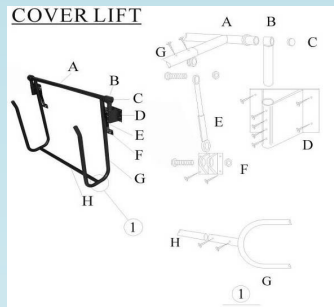

## COVER MAINTENANCE

- Clean the cover with soapy water and make sure do not let the soap water go inside the spa.
- Do not pull off the cover by catching the linker in the middle of the cover, as will easily tear.
- Do not sit, lie or jump on the cover or you will cause damage which is not covered by warranty.

# Trouble Shooting

Description of trouble	Analysis	Solution
An error message appears on the LCD display	<ul style="list-style-type: none"> <li>• Error detected by digital diagnostics function.</li> </ul>	<ul style="list-style-type: none"> <li>• Please check the error message trouble shooting in the control system manual, and then contact your local dealer if you are unable to resolve the issue.</li> </ul>
SPA can't start in any mode	<ul style="list-style-type: none"> <li>• Power off.</li> <li>• Control panel is locked.</li> <li>• Control panel failure</li> </ul>	<ul style="list-style-type: none"> <li>• Check the power switch on or leakage switch is turned on.</li> <li>• Check the control panel is unlocked.</li> <li>• Check the failure code in control system manual for solution, and then contact your dealer to do the maintenance.</li> </ul>
SPA starts automatically	<ul style="list-style-type: none"> <li>• Filtration program is operating.</li> <li>• Heating function is operating.</li> <li>• Anti-freezing function is operating.</li> </ul>	<ul style="list-style-type: none"> <li>• The control system will automatically stop when the program finishes.</li> </ul>
The water pump turns off	<ul style="list-style-type: none"> <li>• The pump running time is more than the system default maximum running time.</li> <li>• The pump motor is overheating protected.</li> </ul>	<ul style="list-style-type: none"> <li>• Repress pump button to restart the pump.</li> <li>• Stop running pump more than 1 hour until cool and then start the pump.</li> </ul>
Pump running after filling spa but no water coming through jets	<ul style="list-style-type: none"> <li>• The jets are closed.</li> <li>• Air blockage in the water pump.</li> </ul>	<ul style="list-style-type: none"> <li>• Check whether the jets are closed. If yes, open it.</li> <li>• Turn pumps on and off several times to drain the blocked air. Unscrew the live union on the water pump to release the air and then screw on tightly.</li> </ul>
Heater heating slowly or failing to heat	<ul style="list-style-type: none"> <li>• Temperature setting is low</li> <li>• Filter cartridge dirty and blocked</li> <li>• No spa cover on the spa causing heat loss</li> <li>• Circulation jets is closed</li> <li>• Heater broken</li> </ul>	<ul style="list-style-type: none"> <li>• Set the temperature up</li> <li>• Clean or replace paper filter core</li> <li>• Put the cover on the spa</li> <li>• Turn on the jets</li> <li>• Contact the local dealer for maintenance</li> </ul>
Weak water flow through the jets	<ul style="list-style-type: none"> <li>• Jets are not fully opened.</li> <li>• Jets are blocked.</li> <li>• Air valve is turned off.</li> <li>• Water diverter closed to the seat.</li> <li>• Water pump ball valve is not fully opened.</li> </ul>	<ul style="list-style-type: none"> <li>• Turn on the jets fully.</li> <li>• Turn counter-clockwise to take off the jets fitting and clean the jets chamber if blocked.</li> <li>• Turn on the air valve switch.</li> <li>• Divert the water diverter to the seat jets wanted.</li> <li>• Check the water pump ball valves are fully opened.</li> </ul>
Uneven water flow from jets	<ul style="list-style-type: none"> <li>• Suctions or filter are blocked.</li> </ul>	<ul style="list-style-type: none"> <li>• Clean the suction or filter.</li> </ul>

# Warranty Information

**IMPORTANT: An annual service with a qualified Spa Technician is required to maintain warranty cover.**

## **Important Usage Warnings - Non Warranty Faults**

Should we ever need to visit you to repair your spa, it is likely that you would be charged the full cost of a repair if we found that the cause was the result poor maintenance or customer negligence. Paying full attention to the issues below will help to reduce the risk of damage to your spa. Please also read your warranty document in full. This can be found at the end of this document.

## **Water Treatment**

One of the most crucial aspects of spa maintenance is water treatment. Poorly treated spas may result in high levels of pH or Water Hardness. Either of these problems may result in limescale build-up which can damage your spa surface, pumps, jets or heaters. If we find a build-up of limescale on your spa, this would not be covered under warranty.

Different chemical packs have different methods of caring for the water. You will need to refer to the guide that came with your chosen chemical pack for exact details on how to treat your water. You can also download a general water treatment guide from our website.

## **Filling Up Your Spa - Air Locks**

The correct way to fill up your spa is to place your hosepipe inside the filter compartment. Some customer place their hosepipe inside the spas main seating area however, doing this may cause a build-up of air inside the heater (known as an air lock). Over time, air locks will cause the heater to fail. This would not be covered under warranty. To avoid this problem ensure you fill up the spa through the filter window. You can tell if you have an air lock by turning on the circulation pump. If no water appears to circulate through the system it is very possible that you have an air lock. To resolve this problem, loosen the unions at the side of the suction end of the circulation pump until water begins to flow through.

# Warranty Information Continued

## **Filters**

Poor filter conditions are one of the biggest causes of faults that are not covered under warranty. Poor filter conditions allow particles to roam in the spas water. These tiny particles can cause damage to the spas components. One of the first things our engineer will check when visiting your spa is the condition of your filter. If we find your filter is in poor condition, your repair will not be covered under warranty.

There are a number of ways of caring for your filter. Crucially, we recommend that you regularly soak your spa in filter cleaner every few weeks. Additionally, we recommend changing your filter every 6-9 months (depending on usage). Some customers purchase a spare filter at the time of ordering and alternate between the two.

## **Use of Cover**

Your spa cover must be used when the spa is not in use. Leaving the cover expose allows leaves, dust etc to enter your spa. These may then be sucked in the spas pipework causing blockages or damaging the equipment. If our engineer finds leaves for example inside your spa, your repair would not be covered under warranty.

## **Caring for Wooden Skirting**

Wood skirting has a tendency to fade and lose its like-new appearance with time. You should re-stain your spa's skirting once every six months. Lightly sand the surfaces to remove any dirt and smoothen rough surfaces. Re-stain wood surfaces using a suitable stain. Do not use varnishes, shellacs, or surface sealants. Warranty on spa skirting is only valid if spas have been regularly stained.

## **Frost Damage**

As water freezes in the winter, it expands. This expansion can cause damage to your spas components and pipework. If you intend to use the spa throughout winter then you must have the frost prevention system turned on. If you do not intend to use the spa throughout winter than the spa must be 'winterized'. Please see our website, or contact us for more information on winterizing your spa. Problems arising from frost damage are not covered under warranty.